

GS4AC45H - GS4AC45L

STANDARD MATERIALS AND CONSTRUCTION

- FRAME:** 16-GA galvanized steel.
- BLADE:** 18-GA galvanized steel on exterior with 22-GA galvanized perforated steel on interior surface. Blades approximately 7½" on centers.
- INSULATION:** Eco-Sound insulation.
- ASSEMBLY:** Riveted and/or welded, with head, sill, and blades contained in jamps.
- SCREEN:** ½" sq. mesh, 19-GA galvanized steel (.041"), when indicated.
- FINISH:** Mill.

OPTIONS

- Flange Frame
- Finish - Baked Enamel, Kynar, Anodize
- Screen - Bird or Insect Screen

NOTES

1. Nominal deductions will be made to the opening size given.

LOUVER SIZES

Min Panel	Max Single Panel
12"W x 18"H	60"W x 96"H

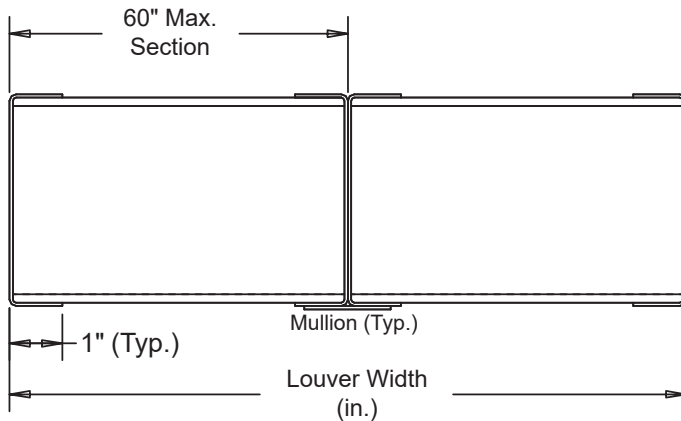
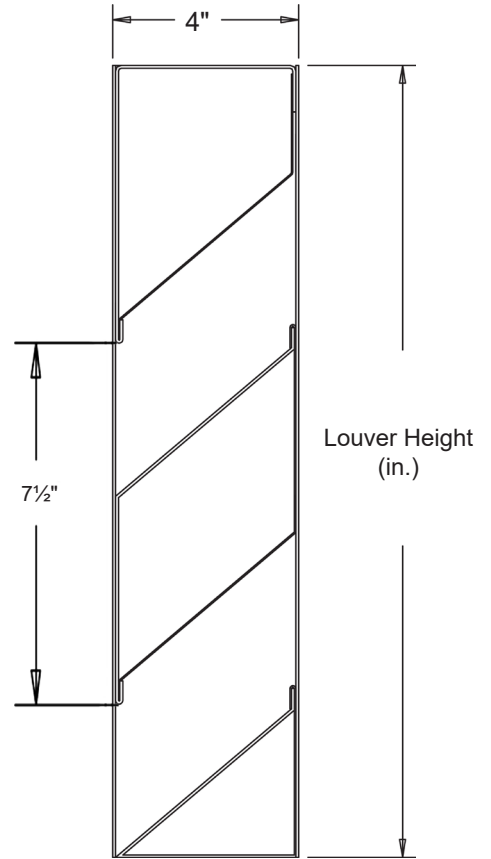

In the interest of product development, Airline Louvers reserves the right to make changes without notice.

												
Item #	Qty	Width	Height	Width	Height	Mullion	Type	Location				Union Made
		Opening Size		Louver Size			Screens					
Arch. / Eng. :						EDR:		ECN:		Job:		
Contractor:												
Project:						Date:		DWN:		DWG:		

GS4AC45H - GS4AC45L

PERFORMANCE DATA

Test of a 48" x 48" sample by an AMCA Registered Laboratory according to AMCA Standard 500 shows low water penetration. Tests show less than .02 oz. per sq.ft. water penetration at 787 fpm (Free Area Velocity) with less than .11 in. w.g. pressure drop (intake) and .12 in. w.g. pressure drop (exhaust). Intake air is converted to standard air density.

An AMCA Registered Laboratory is a laboratory equipped and staffed to conduct tests according to the appropriate AMCA test method and which is licensed as an AMCA Registered Laboratory.

Ratings do not include effects of a screen.

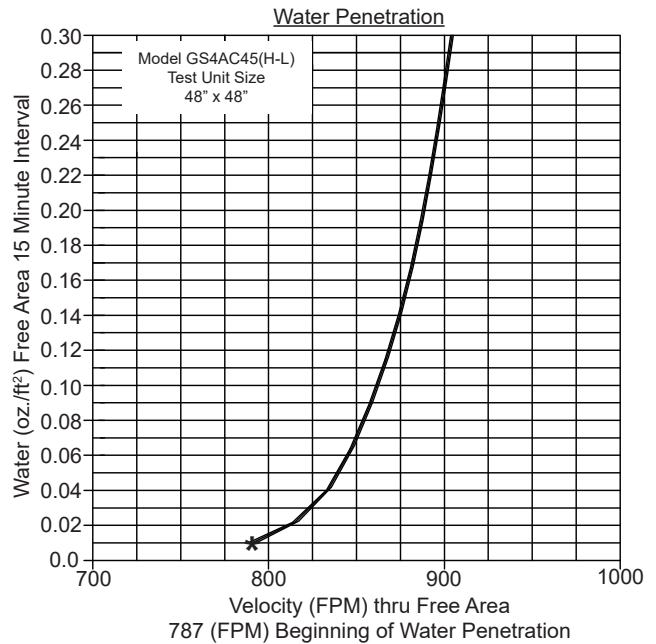
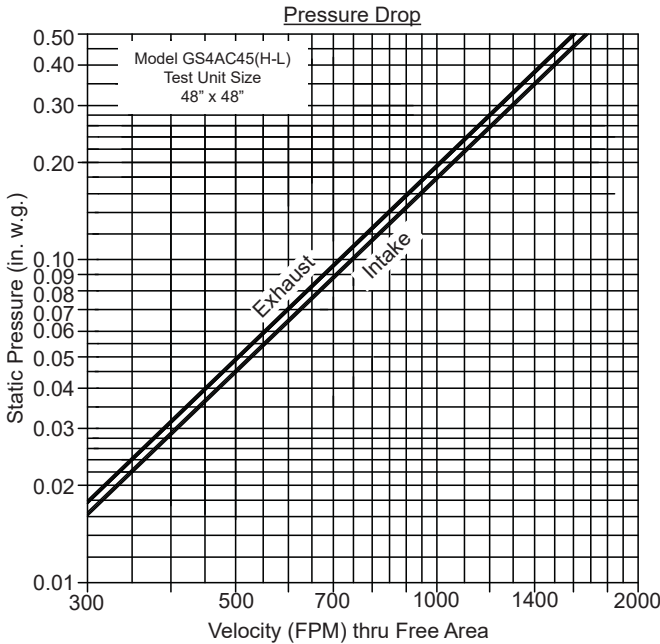

Free Area (sq.ft)

		Width (in.)								
		12"	18"	24"	30"	36"	42"	48"	54"	60"
Height (in.)	24"	.47	.75	1.03	1.32	1.60	1.88	2.16	2.24	2.72
	36"	.68	1.09	1.50	1.91	2.32	2.73	3.13	3.54	3.95
	48"	1.02	1.63	2.24	2.85	3.46	4.07	4.51	5.29	5.91
	60"	1.19	1.91	2.62	3.34	4.05	4.77	5.48	6.20	6.91
	72"	1.53	2.45	3.37	4.29	5.21	6.13	7.05	7.97	8.89
	84"	1.72	2.76	3.79	4.83	5.86	6.90	7.93	8.96	10.00
	96"	2.04	3.27	4.50	5.72	6.95	8.16	9.40	10.63	11.85

The Model GS4AC45 Acoustical Louver low frequency and high frequency performance data is presented in two separate tables. Review the appropriate table and select the attenuation value for the design noise criteria corrective action required.

Model GS4AC45L (Low Frequency)

Octave Band	1	2	3	4	5	6	7	8
Frequency (Hz)	63	125	250	500	1000	2000	4000	8000
Free Field Noise Reduction	12	14	12	12	9	11	13	15

Model GS4AC45H (High Frequency)

Octave Band	1	2	3	4	5	6	7	8
Frequency (Hz)	63	125	250	500	1000	2000	4000	8000
Free Field Noise Reduction	8	7	9	10	14	16	16	18